

GRINDER/BUFFER CABINET

Model 40089

OPERATING INSTRUCTIONS



3491 Mission Oaks Blvd., Camarillo, CA 93011
Visit our Web site at <http://www.harborfreight.com>

Copyright © 2002 by Harbor Freight Tools®. All rights reserved. No portion of this manual or any artwork contained herein may be reproduced in any shape or form without the express written consent of Harbor Freight Tools.

For technical questions please call 1-800-444-3353

SPECIFICATIONS

ITEM	DESCRIPTION
Body Construction	Body: Formed and Stamped Sheet Steel
Finish	Black Powder Coat
Overall Dimensions	34-1/4"H X 15-3/4"L X 12-3/8"W
Top Mounting Holes	3/8"W X 2-3/4"L (6X Slotted Holes)
Base Mounting Holes	308" Dia. (4X)
Lower Shelf	13-3.8" X 12-3/8"
Middle Shelf	12-1/8" X 12-3/8"
Top Shelf	10-5/8" X 12-3/8"
Top Dimensions	12-7/8"W X 10"L X 1-7/8"H
Overall Weight	47 Lbs.

SAVE THIS MANUAL

You will need the manual for the safety warnings and precautions, assembly instructions, operating and maintenance procedures, parts list and diagram. Keep your invoice with this manual. Write the invoice number on the inside of the front cover. Keep the manual and invoice in a safe and dry place for future reference.

SAFETY WARNINGS AND PRECAUTIONS

1. **KEEP PRODUCT USAGE AREA CLEAN.** Cluttered areas invite injuries.
2. **KEEP CHILDREN AWAY FROM PRODUCT USAGE AREA.** Do not allow children to climb on this product or play around tools or supplies.
3. **DO NOT USE THIS PRODUCT IF UNDER THE INFLUENCE OF ALCOHOL OR DRUGS.** Read warning labels on prescriptions to determine if your judgement or reflexes are impaired while taking drugs. If there is any doubt, do not attempt to use this product.
4. **STAY ALERT.** Watch what you are doing at all times. Use common sense. Do not use a Buffer or Grinder mounted on this product when you are tired or distracted.
5. **CHECK FOR DAMAGED PARTS.** Before using this product, carefully check that it will operate properly and perform its intended function. Check for damaged parts and any other conditions that may affect its operation. Replace or repair damaged or worn parts immediately.
6. **DO NOT MODIFY THIS PRODUCT.** This product is designed to support a Grinder or Buffer. Do not modify this Cabinet in an attempt to use it for other purposes.
7. **REPLACEMENT PARTS AND ACCESSORIES.** When servicing, use only identical replacement parts. Only use accessories intended for use with this product. Approved accessories are available from Harbor Freight Tools.
8. **USE THIS PRODUCT** only for its intended use, as described in this manual. Do not use attachments or modify it in any way.
9. **BE SURE** to use proper hardware (not included) to secure Grinder or Buffer.

NOTE: Always read and adhere to all warnings and instructions provided in the instruction manual of the buffer or grinder being used.

WARNING: The warnings, cautions and instructions discussed in this instruction manual cannot cover all possible conditions and situations that may occur. It must be understood by the operator that common sense and caution are factors which cannot be built into this product, but must be supplied by the operator.

UNPACKING

When unpacking, check to make sure all parts shown on the Parts List (page 4) are included. If any parts are missing or broken, please call Harbor Freight Tools at the number shown on the cover of this manual as soon as possible.

ASSEMBLY INSTRUCTIONS

NOTE: All parts below refer to the parts listed on page 4 of this manual.

Assembly

1. To assemble Steel Grinding/Buffering Cabinet with three storage shelves you must first lay out all parts and hardware on a clean surface.
2. Identify the Top Shelf (#6), the two Side Panels (#2A, #2B, right and left), the Base (#1), and the Back Panel (#5).

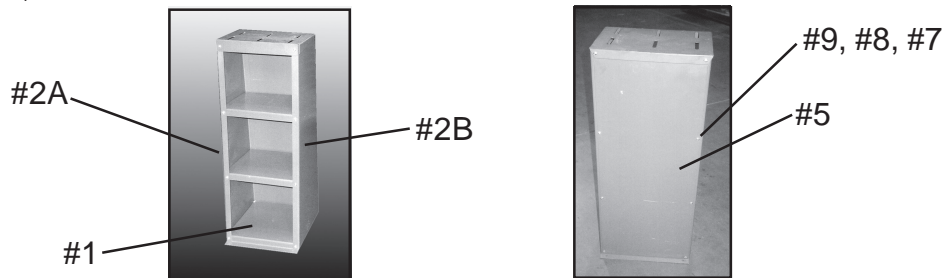

3. Starting with the Base (#1), fit the side panels over the Base, lining up the holes. Use the Bolt (#9) through the holes. Secure with Washer (#8) and Nut (#7). Repeat with Side Panels (#2A & #2B). Attach Back Panel (#5) to Side Panels and Base in the same way.
4. Slide in Shelves (larger on bottom and graduating up to smallest) (C & D). Secure each shelf with Bolts (#9), Washers (#8) and Nuts (#7) to Side Panels and Back Panel.

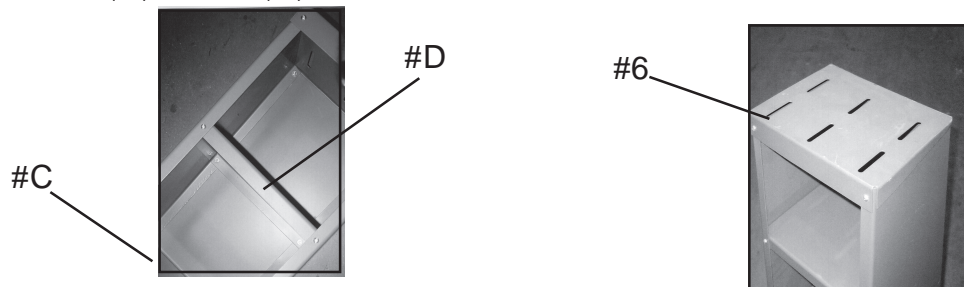

5. Attach Top (#6) aligning with remaining holes. With Bolt (#9) through the holes, secure with Washer (#8) and Nut (#7) through front and back of Cabinet.
6. Choose where you want to place Cabinet permanently. Anchor through holes in Base (#1) with hardware for cement or wood flooring, depending on where you choose to mount Cabinet so it is secure during Grinding or Buffering for a strong sturdy work surface. (Hardware not included.)
7. Attach your Buffer or Grinder through the 6 top mounting holes (3/8" H X 2-3/4" L). Hardware will be required (not supplied). A non flammable rubber pad (not supplied) for insulation, is recommended between the Cabinet Top and the Buffer or Grinder. This pad will help reduce vibration.

PART #	DESCRIPTION	QTY
1	Base	1
2A	Left Side	1
2B	Right Side	1
C	(larger) Shelf	1
D	(smaller) Shelf	1
5	Back Panel	1
6	Top (with slotted holes)	1
7	Nut (10MM)	16
8	Washer	16
9	Bolt (M6 X 1,00MM Round Flat)	16

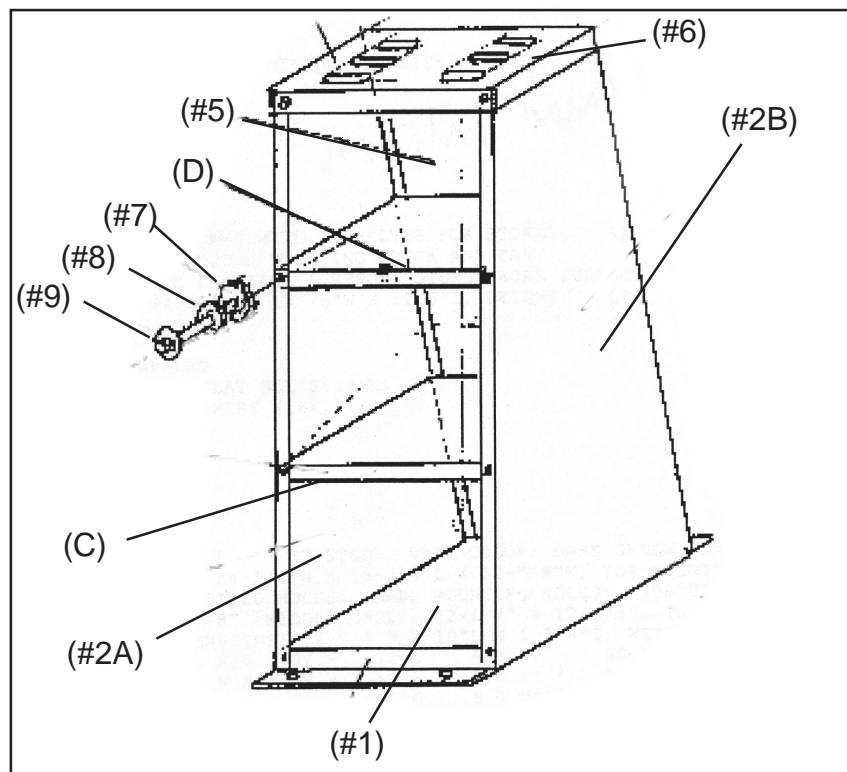

MAINTENANCE

1. For better and safer performance, keep all parts of this product clean and dry at all times.

PLEASE READ THE FOLLOWING CAREFULLY

THE MANUFACTURER AND/OR DISTRIBUTOR HAS PROVIDED THE PARTS DIAGRAM IN THIS MANUAL AS A REFERENCE TOOL ONLY. NEITHER THE MANUFACTURER NOR DISTRIBUTOR MAKES ANY REPRESENTATION OR WARRANTY OF ANY KIND TO THE BUYER THAT HE OR SHE IS QUALIFIED TO MAKE ANY REPAIRS TO THE PRODUCT OR THAT HE OR SHE IS QUALIFIED TO REPLACE ANY PARTS OF THE PRODUCT. IN FACT, THE MANUFACTURER AND/OR DISTRIBUTOR EXPRESSLY STATES THAT ALL REPAIRS AND PARTS REPLACEMENTS SHOULD BE UNDERTAKEN BY CERTIFIED AND LICENSED TECHNICIANS AND NOT BY THE BUYER. THE BUYER ASSUMES ALL RISK AND LIABILITY ARISING OUT OF HIS OR HER REPAIRS TO THE ORIGINAL PRODUCT OR REPLACEMENT PARTS THERETO, OR ARISING OUT OF HIS OR HER INSTALLATION OF REPLACEMENT PARTS THERETO.